

Preparation

Prior to every event each entrant should review provided tech sheet and examine their car ensuring that all requirements are met. All competition vehicles must pass a tech inspection before being allowed on the track.

Safety Equipment

All Drivers

1. All drivers must have a properly fitted helmet with a Snell Rating of SA2005 or newer.
2. Long pants, t-shirt, and closed toe shoes are required at a minimum.
3. No open toed shoes, shorts, or tank tops will be allowed.
4. OEM seat belts shall be permitted only if an OEM seat is used. If an aftermarket seat is to be utilized a racing harness must be used. The harness must conform to SFI specification 16.1 or FIA specification 8853/98. Harnesses bearing an SFI rating expire December 31st of the second year after the year of manufacture. Harnesses bearing an FIA rating must be replaced by the fifth year after production though it is recommended that it be replaced every third year. The expiration date, instead of the date of manufacture, is printed on the FIA label.

Tandem Drivers

1. In addition to the aforementioned requirements, tandem drivers are required to wear a racing suit with a SFI rating that is up to date. If single layer, nomex underwear is necessary.

Tech Requirements:

Wheels and Tires – Tires and rims should be in good shape, free of any major defects (e.g. cracks). There should not be any cords/belts exposed, bubbles, or any other visible damage to the tires. All lug nuts must be present and properly fastened. Hubcaps and beauty rings are not permitted and must be removed prior to tech inspection. At anytime during an event if a Street Life Tour Staff Member deems the tires on an entrant's vehicle are unfit for competition/practice he/she will be asked to change the affected tire/s before being allowed to re-enter the track.

Steering and Suspension – All components should be in good condition and should have little or no play. Steering should have minimal play and all components in overall good condition. The front and rear wheel bearings should be tight and have zero play. Suspension components should have little or no play.

Engine Bay – The engine, as well as all accessories, shall be free of any fluid leaks. A radiator catch tank of at least one liter should be used, factory catch tanks are acceptable. All vents and oil breathers should either terminate in a catch tank or return to the engine. Any hose carrying fluids should be in good condition and free of any cracks or other damage. No exposed wires will be permitted, powered or not.

Brakes – The braking system must be in proper working order and be able to stop the vehicle in a reasonable distance. All brake lines must be in good condition and the fluid level above the minimum level as specified by the manufacturer. Brake pedal pressure should be adequate. A minimum of two OEM-style working brake lights are required. Aftermarket OEM-style lights are acceptable. (e.g. Euros, clear, etc.)

Battery – The battery should be securely mounted to the car. Bungie cords, straps, or rope will not be accepted. The positive terminal on the battery must be covered by appropriate means. Tape of any sort will not be accepted. Factory-style covers are recommended. If the battery is located in the driver's compartment it should be fully enclosed, securely fastened, and properly vented.

Gas Cap – It is necessary for all vehicles to utilize a gas cap to prevent fuel spillage.
Exposed Wires – No exposed wires of any sort will be permitted in the engine bay or driver's compartment regardless if they are powered or not.

Seats – The driver's seat must be fastened to the car in a manner that will withstand a significant impact. If aftermarket seats are utilized they should be fastened to the vehicle per the manufacturer's specifications. Passenger seats must meet the same requirements however they need not match the driver's seat.

Loose Objects – All loose items in the driver's compartment and trunk must be removed. E.g. Floor mats, spare tire and jack, tools, trash, clothing, all other objects that are not securely fastened to the vehicle.

Hoses in Driver's Compartment – Any hose that passes through the driver's compartment carrying a liquid or gas must either be a metal hard line or braided stainless. Cold water lines such as those used for driver suits are exempt from this rule.

Exhaust – The engine exhaust must exit behind and away from the driver. Open downpipes will not be permitted.

Body Panels – All major body components (windshield, hood, fenders, doors, trunk lid, quarter panels) must be present and securely fastened to the vehicle. Front and rear bumpers along with side skirts may be removed.

Roll Cage – A roll cage is not required to participate in an SLT event. However, a roll cage is required for all entrants who wish to tandem.

Construction Material – Roll cages may be constructed of either Seamless Mild Steel (DOM) or Seamless Chromoly (4130) tubing appropriately sized for the weight of the vehicle. Mild Steel (ERW) is not permitted.

Tubing Diameter – Tubing diameter is determined by the weight of the vehicle, race prepped, minus driver and fuel. Diameter per weight class is as follows per Formula D Rules.

Up to 3500 lbs – 1.500” x 0.095” Chromoly (4130) or Mild Steel (DOM)

Mounting Points – The roll cage shall be mounted to the floor of the chassis in at least six (6) points with either plates or boxes. All attachment points must be mounted to these plates or boxes and be welded three-hundred sixty (360) degrees. Mounting plates can be no smaller than two (2) inches on any side and have a minimum thickness of 0.080 inch.

Mounting Points – Bolt-in Cage – The roll cage shall be fastened to the floor of the chassis in at least six (6) points. The attachment points of a bolt-in cage to the body must use plates, 3/16 inch thick minimum, to sandwich the body. A minimum of three (3) bolts are required per mounting plate. Each plate must be at least 3/16 inch thick. All hardware must be at least SAE Grade 5 or better and be a minimum of 5/16 inch diameter.

All nuts must be held securely by safety wire, lock washer, nylock, or jam nut.

Welds – All welds must conform to the American Welding Society D1.1:2002, Structural Welding Code, Steel Chapter 10, Tubular Structures. All welds shall be continuous, three-hundred sixty (360), around each mounting point of each tube. All welds shall be visually inspected and must meet the following criteria in order to be acceptable.

1. All welds shall be free of any cracks.
2. Thorough penetration must exist between the tube and base material.
3. All craters, if any, shall be filled to the cross section of the weld.
4. Undercut shall be no more than 0.01 inch deep.

Inspection Hole – All tubes must have a 3/16 inch, but no greater than 1/4 inch, hole drilled in a non-critical area as to verify wall thickness.

Bends – No part of any tube shall show signs of crimping or wall failure. All bends must be mandrel bends, crush bends are not accepted.

Main Hoop – The roll cage main hoop should be constructed from one continuous length of tubing and be as close to the full width of the interior and as close to the roof as possible with no more than four (4) bends totaling no more than one hundred eighty (180) degrees +/- ten (10) degrees.

Diagonal Brace – At least one (1) diagonal brace shall be used during construction of the main hoop and be in the same plane as the main hoop. The diagonal should be in one continuous path. Refer to diagram 1.0 One end should attach to the mounting plate, or main hoop as close to the mounting plate as possible, diagonally opposed to the driver's head. The other end shall mount to the corner, or horizontal part, of the main hoop above the driver's head, within twelve (12) inches of the driver's-side corner. It is recommended the diagonal brace be one continuous length of tubing.

Diagram 1.0

Diagram 1.0

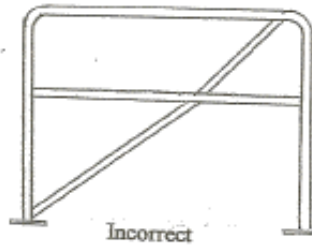
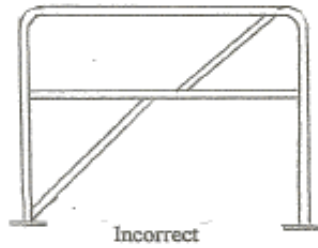
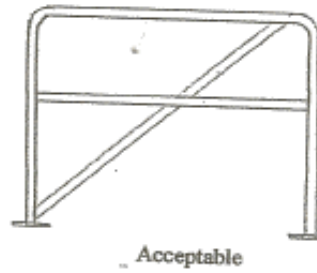
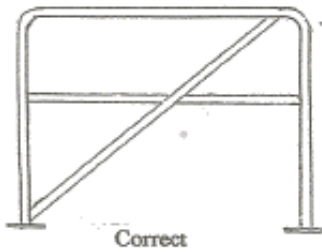

Harness Bar – The main hoop shall contain a horizontally mounted harness bar, which is to be constructed of like material, and be located no higher than shoulder height. The harness bar must extend from each leg of the main hoop and intersect the diagonal brace.

Front/Side Hoops/Halo – All hoops and/or down tubes must be mounted to the floor. Three different configurations are allowed.

Side Hoop – Each side hoop is one (1) continuous length of tubing. Starting at the floor, as forward as possible, and following the “A” pillar and door frame back to the main hoop. There shall be a tube connecting each of the two (2) side hoops at the top of the windshield mounted as close to the roof as possible. Each side hoop shall contain no more than four (4) bends totaling no more than one-hundred eighty (180) degrees.

Diagram 2.0

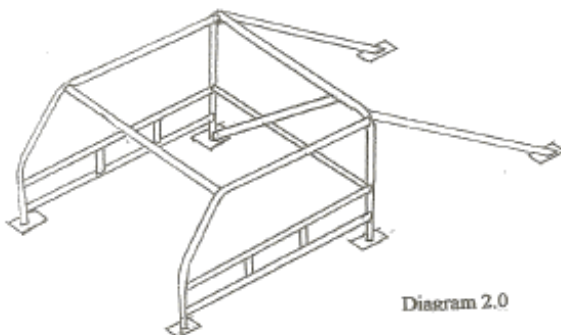

Halo Hoop – A Halo Hoop is one (1) continuous length of tubing. The halo extends from the main hoop, in a forward direction, following the roof line above the doors and windshield. The Halo must be connected to the floor with two (2) front down tubes. The Halo bar must not contain more than four (4) bends totaling no more than one-hundred eighty (180) degrees.

Diagram 2.1

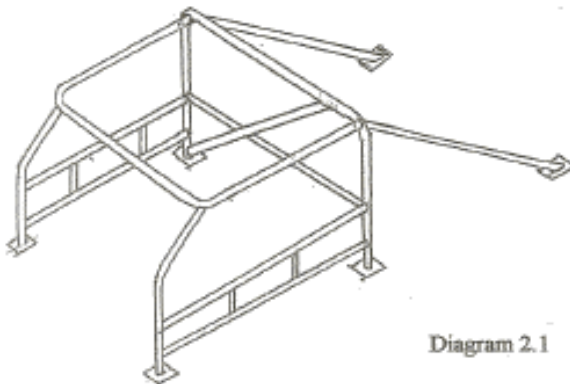

Front Hoop – A front hoop is one (1) continuous length of tubing. Starting at the floor, as far forward as possible, and then following the “A” pillar up to the roof. Then, following the roof/windshield line across the vehicle and down alongside the other “A” pillar to the floor. No more than four (4) bends totaling no greater than one hundred eighty (180) degrees will be permitted. The front hoop must be connected to the main hoop by means of two (2) horizontal bars, one (1) on each side above the doors.

Diagram 2.2

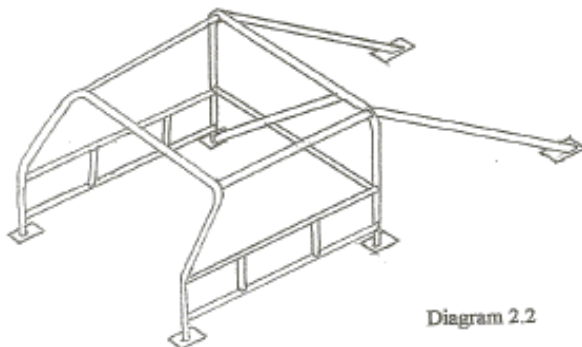

Rear Braces – The main hoop must have two (2) braces extending to the rear. The braces must attach as near to the top of the main hoop as possible and no more than six (6) inches below the top. The rear braces must not contain any bends. There must be a minimum of thirty (30) degrees between the rear braces and the main hoop.

Diagram 3.0. When viewed from the top the rear braces are to form no more than a one-hundred five (105) degree angle Diagram 3.1 and no less than a seventy-five (75) degree angle.

Diagram 3

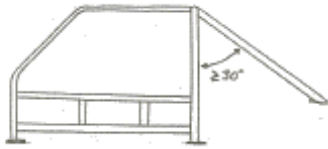

Diagram 3.0

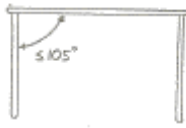

Diagram 3.1

Main Hoop Top View

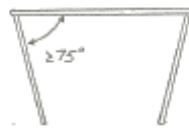

Diagram 3.2

Main Hoop Top View

Door Bars – All cars are required to have at a minimum two (2) bars across each front door opening. The door bars may run parallel to one another or form an “X”. Diagram 4.0. If a parallel design is used a minimum of two (2) vertical bars must be installed, joining the upper and lower bars.

Diagrams 4

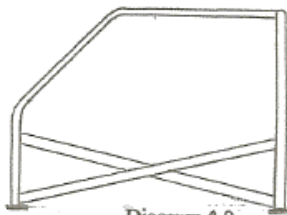

Diagram 4.0

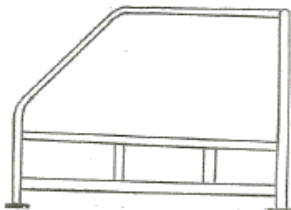

Diagram 4.1

Padding – All roll cage surfaces that may contact the driver should be padded with high-density padding. It is not required, though recommended, that all padding meet SFI specification 45.1.